

Winch 25 Double

Item no .221

TECHNICAL DATA

MODEL:	Winch 25 Double
ITEM NO.:	221
DIMENSIONS (L x W x H):	687 x 229 x 355 mm / 27.0 x 9.01 x 14.0 in (Without mounting clamp)
POWER SUPPLY:	200-240 V AC 50-60 Hz
POWER CONSUMPTION:	3000 Watt
POWER INLET/OUTLET:	Neutrik powerCON TRUE1 NAC3MPX (F/M)
DMX CONTROL SIGNAL:	DMX 512 1990 + DMX512A / 6 channels used
DMX CONNECTION:	5 pole XLR, male & female
LIFTING HEIGHT:	10 m (33 ft.)
LIFTING CAPACITY:	25 kg (55 lb)
LIFTING SPEED:	Variable, 5-40 cm/s (2.0-15.7 in/s)
MINIMUM LOAD:	1.0 kg (2.2 lb)
NOISE EMISSION (AT 1 m):	~ 50 dB
AMBIENT TEMPERATURE:	0-40 °C (32-104 °F)
OWN WEIGHT	32 kg (70.5 lb)
MOUNTING CLAMP	2 x slim eye coupler 50 mm (2 in)
MOTOR:	230 V AC, 0.25 kW 2800 rpm
DUTY CYCLE:	Maximum 30% at max. load

LIFTING WIRE SPECIFICATIONS:

LIFTING WIRE:	2 mm /5/64 in) 7x7 PP coated galv. Steel wire (EN 12385-4)
MINIMUM BREAKING LOAD (WIRE):	280 kg (2.75 kN / 618 lb)
WIRE SAFETY FACTOR:	Minimum 10
WIRE FLEET:	76 mm (3.0 in)
WIRE FLEET ANGLE:	None

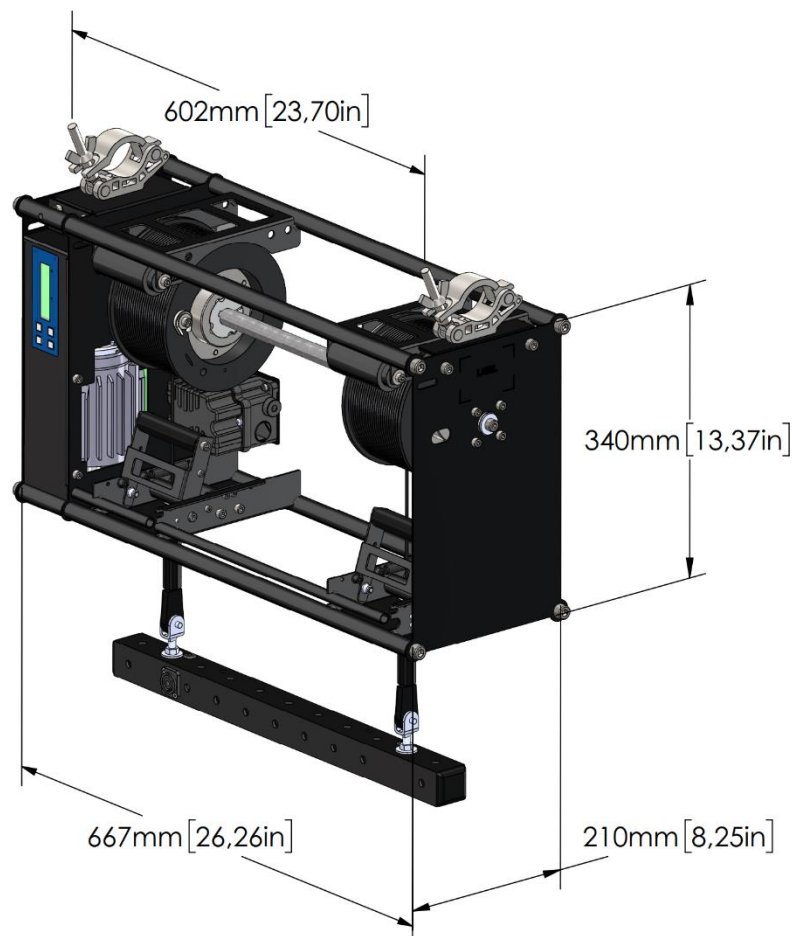

**FRONT VIEW
TOP POSITION**

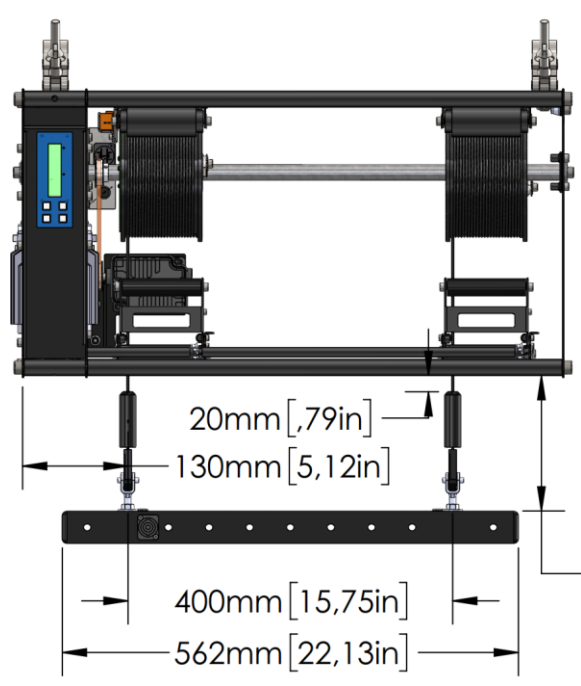

**FRONT VIEW
BOTTOM POSITION**

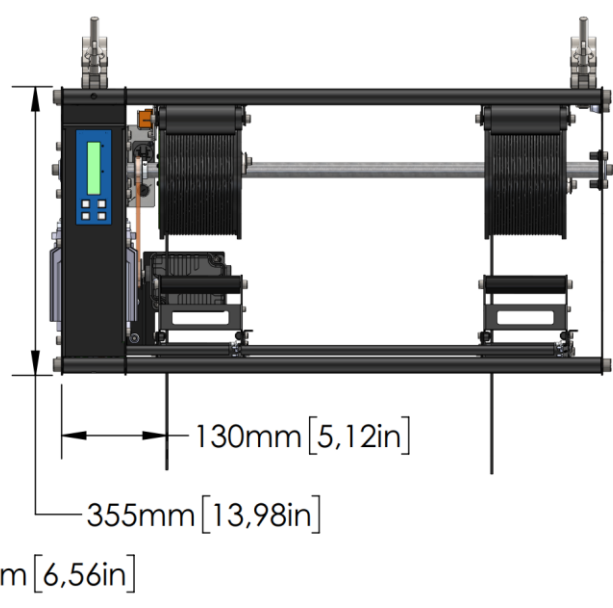

TOP VIEW

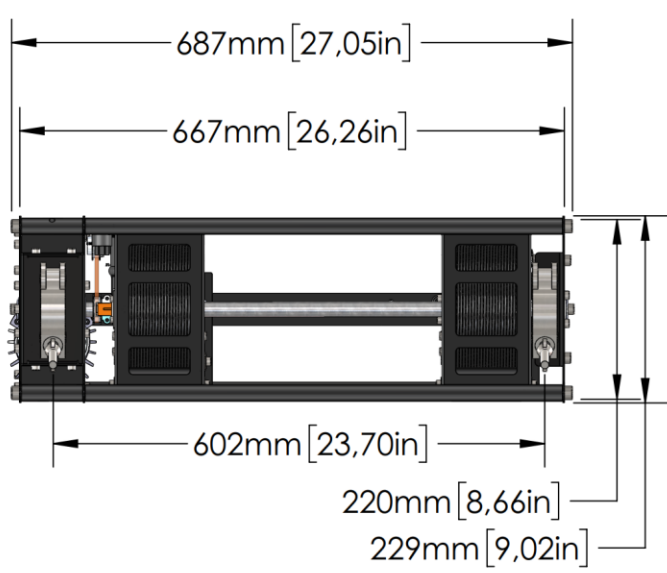

SIDE VIEW

